

Main Unit Specifications

Model: OKS-1400HS

Overall Dimensions (mm)	Width	Depth	Height
	1400mm	820mm	970mm
Power Consumption (5kW total)	Pump	Heater	
	1.5kW	1.5kW×2	
Connection Diameter (A)	Water Supply	Drain	
	20A	40A	

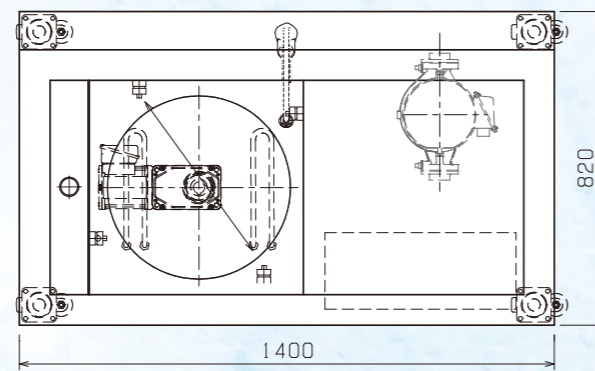

OKS MICRO NANO BUBBLE PARTS WASHER

*Included Accessories: 1 standard cleaning basket.
 *Temperature Adjustment:
 Adjustable from room temperature up to 80°C (thermostat built-in)

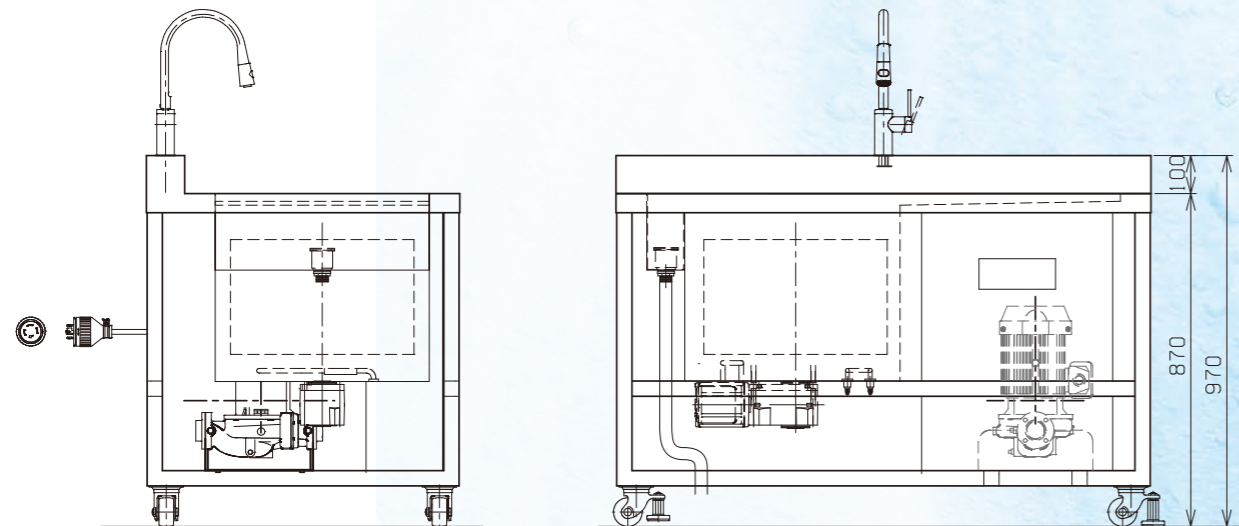

OKS-1400HS

Achieves "Low Concentration" × "High Cleaning Power" × "Improved Rinsability"!
 A cost-effective, phosphate-free detergent with low environmental impact.

Specialty Detergents for Sanitary Parts

● OKS-D-FL-100

Application: For food and cosmetics industries
 Usage concentration: 0.2% – 1.0%
 pH: Alkaline
 Form: Liquid
 Packaging: 4L plastic container × 4 containers per box



● OKS-D-CL-100

Application: For pharmaceutical and cosmetics industries
 Usage concentration: 0.2% – 2.0%
 pH: Neutral
 Form: Liquid
 Packaging: 18L plastic container



*Jointly developed with a major chemical manufacturer



Hole Solutions Company

Kobe Headquarters

4-5-5, Aioi-cho, Chuo-ku, Kobe 650-0025 Japan
 T : +81-78-351-2531 E : info@okutanikanaami.co.jp
 URL : https://www.okutanikanaami.co.jp/

OKS 1895



Portal Site



ODS Sanitary Strainer

MICRO
NANO
BUBBLE



Automating manual cleaning of sanitary parts! Introducing a micro-nanobubble cleaning solution that saves **time** and **money**.

Effectiveness of Introduction

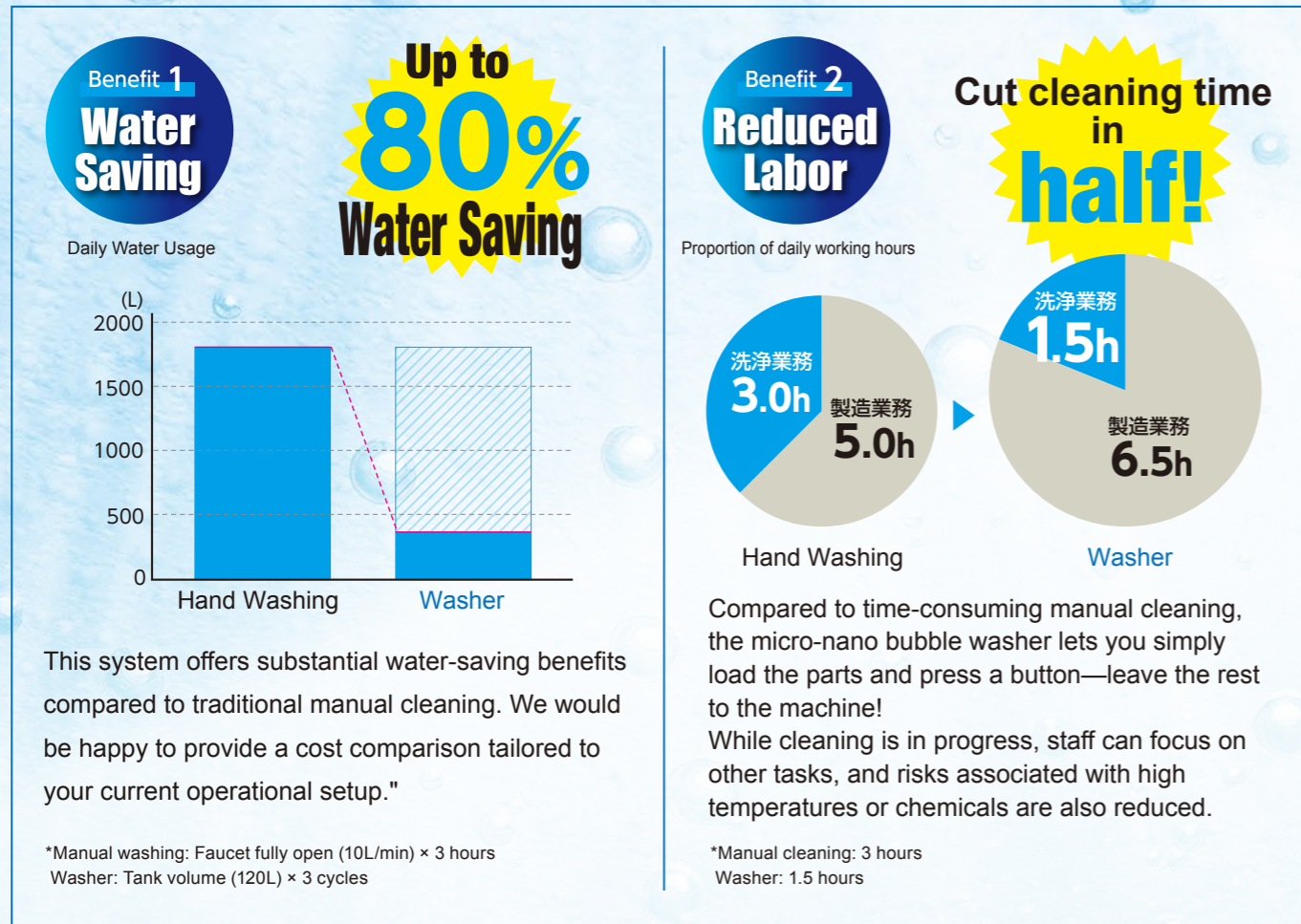

What Are Micro-Nano Bubbles?

Micro-nano bubbles are tiny gas bubbles dispersed in liquid. Bubbles with a diameter of 10 micrometers (1/100 mm) to several tens of micrometers are referred to as "microbubbles," while those smaller than a few hundred nanometers are called "nanobubbles."

How Micro-Nano Bubbles Clean

Contaminants dispersed in water are difficult to lift on their own. Micro-nano bubbles adsorb and lift them through interactions with the water's surface tension. When they reach the surface, the micro-nano bubbles burst, leaving only oils and debris on the water's surface. Combined with direct cleaning from regular-sized bubbles released through multiple nozzles in the tank, the micro-nano bubbles enhance overall cleaning performance.

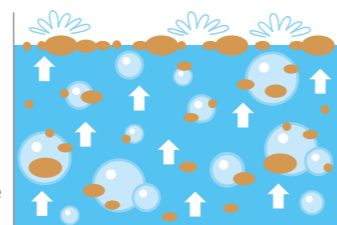

Four Key Features

Thorough cleaning of sanitary parts from all angles with a 360° approach!

1 Powerful Cleaning from All Directions

High-power nano-bubbles are sprayed from our uniquely designed nozzles in four directions, thoroughly cleaning even the hard-to-reach areas of the wash basket.

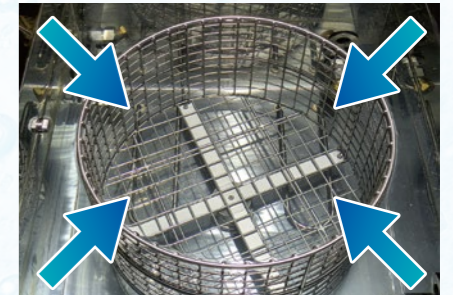

2 Efficient Cleaning with Oscillating Rotation

During the wash cycle, the basket holding various parts rotates and oscillates, enabling efficient and uniform cleaning.



3 Compatible with Small and Delicate Parts

Even small items like screws, gaskets, and electrodes can be cleaned effectively when placed in dedicated baskets.

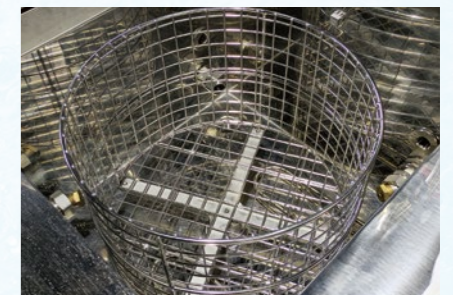

4 Recirculating Wash System to Prevent Recontamination

Floating debris in the water is filtered out through our original strainer system during circulation, preventing it from redepositing on parts and ensuring consistently clean results.

